



SHURFLO AQUA KING™ II PREMIUM 4.0

MARINE FRESH WATER PUMP – PRODUCT TECHNICAL DATA SHEET

OEM: 4148-163-A75
 AFTERMARKET: 4148-163-E75



APPLICATION:

Multi-fixture Marine fresh water pump installation.
 This pump may be used for general fresh water transfer

PUMP DESIGN:

Type: 4 Chamber Diaphragm pump
 Check Valve: (1-way operation) Prevents Reverse Flow
 Ports: ½"-14 NPSM-Male
 Liquid: 130°F [54°C] Max
 Dry-Prime: 6 feet [1.82 M]
 Run Dry: Yes
 Inlet Pressure: 30 PSI Max. [2.06 Bar]

Aftermarket model includes:

- 50 Mesh strainer: swivel straight adapter ½-14 NPT (hex-wing nut) X ½-14 NPS (male)
- Fittings: swivel straight adapter ½-14 NPT (hex-wing nut) x ½ barb (Qty. 2)

ELECTRICAL:

Motor: 24V DC Permanent Magnet, Intermittent Duty.
 Protection: Thermal Overload, Automatic Restart
 Leads: 14 AWG, 14 ¾" [37 cm] Red +, 15" [38 cm] Black
 Fuse: 7.5 Amp Recommended
 Control: Shut-Off 55 PSI [3.8 Bar] ± 2 PSI [0.13 Bar]
 Re-start 40 PSI [2.8 Bar] ± 2 PSI [0.13 Bar]
 Maximum By-Pass 65 PSI [4.5 Bar] ± 2 PSI [0.13 Bar]

MATERIALS OF CONSTRUCTION:

Housings: Polypro
 Valves/Seals: EPDM
 Diaphragm: Santoprene
 Hardware: Stainless Steel

AGENCY APPROVALS:

Ignition Protection 8846, CE, IMCI Certified

SHIPPING INFORMATION:

Approx. Net Weight: 7.9 Pounds [3.5 Kg] ea.
 Carton Qty.: 6
 Approx. Carton Weight: 50 Lbs. [22.6 Kg]
 Approx. Carton Size: 24"L X 18"W X 6"H [61cm x 46cm x 15cm]
 Retail (individual) box: 12"L X 6"W X 6"H [30cm x 15cm x 15cm]

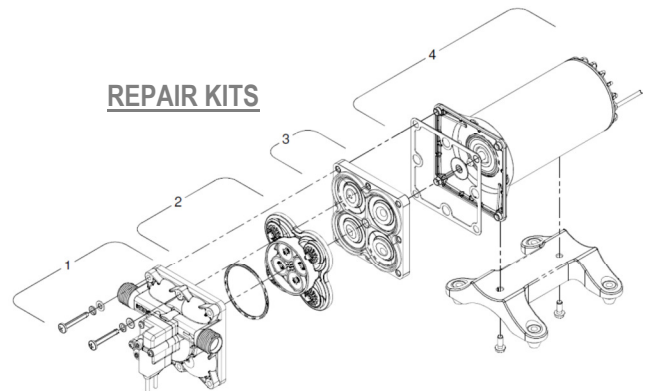

REPAIR KITS

Number	Description	Part Number
*1	Upper Assembly	94-801-10
2	Valve Assembly	94-800-01
3	Drive Assembly	94-801-02
4	Motor/Gasket	94-71-001-03
*1,2,3	Pump Head	94-801-11
Not Shown	Check Valve	94-800-03

*With preset switch and by-pass adjustment

RELATED DOCUMENTS:

Catalog: MS-030-140
 App Guide Sheet: MS-020-005
 Installation Manual: 911-1026
 Aftermarket Warranty: 911-1045

TYPICAL PERFORMANCE AT 24V

PRESSURE		FLOW		CURRENT
BAR	PSI	GPM	LPM	AMPS
0	0	4.0	15.1	1.5
0.7	10	3.5	13.2	2.5
1.4	20	3.2	12.1	3.1
2.1	30	2.7	10.2	3.7
2.8	40	1.6	6.0	4.2
3.4	50	0.80	3.02	4.8
4.1	60	0.15	0.56	5.2
4.5	65	0	0	5.3

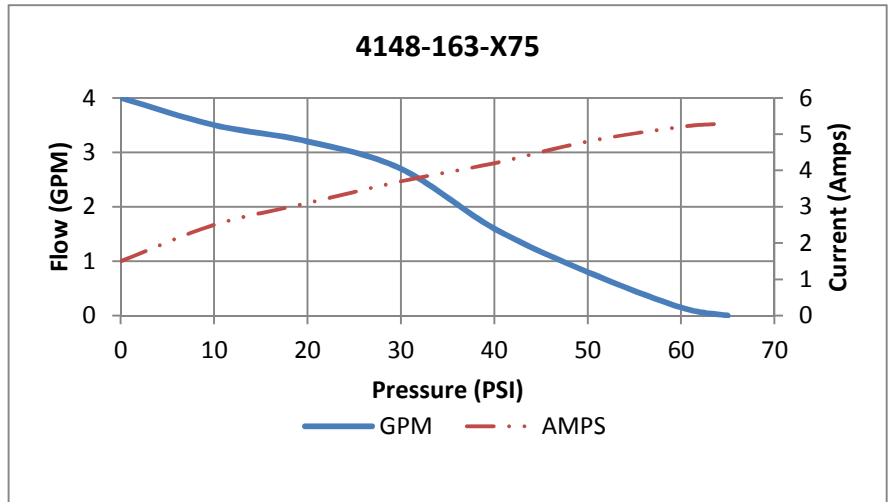

DIMENSIONS:

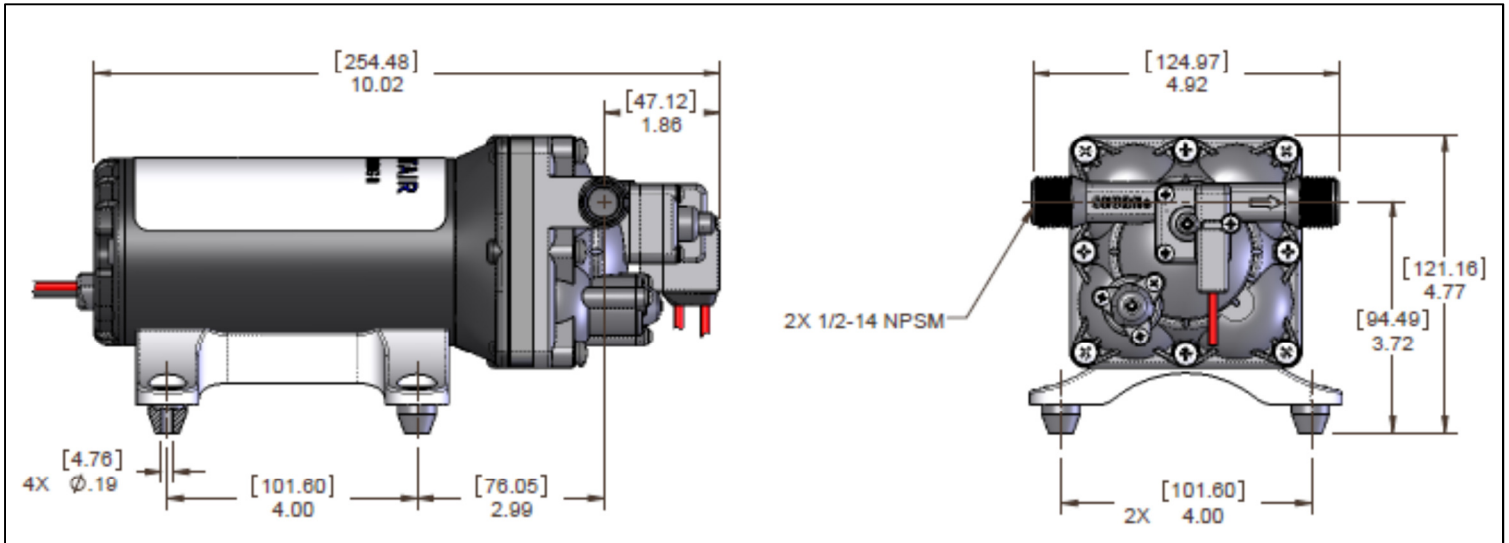

FLOW MANAGEMENT SOLUTIONS

3545 Harbor Gateway South, Suite 103, Costa Mesa, CA 92626, (800) 854-3218 www.SHURFLO.com

All Pentair trademarks and logos are owned by Pentair, Inc. All other brand or product names are trademarks or registered marks of their respective owners. Because we are continuously improving our products and services, Pentair reserves the right to change specifications without prior notice. Pentair is an equal opportunity employer.